

To: DIGI-KEY

Issue No. : 2007E032-1
Date of Issue : May. 22 2007
Classification : New , Changed

PRODUCT SPECIFICATION FOR APPROVAL

Product Description : Electric Double Layer Capacitor
Customer Part Number :
Product Part Number EECHZ0E475 (HZ Series)
Country of Origin : Japan
Marking of the Origin : Printed on the packaging label
Applications : It has the intention of being used for a general electronic
Circuit given in a notice matter (limitation of a use).
On the occasion of application other than the above, even
person in charge of our company needs to inform in advance.

※ If you approve this specification, please fill in and sign the below and return 1copy to us.

Approval No	:	
Approval Date	:	
Executed by	:	_____
		(signature)
Title	:	
Dept.	:	

Capacitor Business Unit
Panasonic Electronic Devices Co., Ltd.
25.Kohata-nishinaka..Uji City,
Kyoto, 611-8585, Japan
Phone (0774)32-1111

Phone : +81-774-33-2640(Direct)
Fax : +81-774-33-4924

Prepared by : Engineering Group
GC Engineering Team

Contact Person :
Signature _____
Name(Print) Takenori Izawa
Title : Engineer

Checked by :
Signature _____
Name(Print) Nario Niibo
Title : Manager

Authorized by :
Signature _____
Name(Print) Shigeyoshi Iwamoto
Title : General Manager of Engineering
No.3818670 20202211

Panasonic

Product Specification	EGC-HZ-475-1-1																								
Electric Double Layer Capacitor HZ series	Page No. Contents																								
<p><u>Contents</u></p> <table> <tr> <td>Notice matter</td> <td>P.1</td> </tr> <tr> <td>Scope</td> <td>P.2</td> </tr> <tr> <td>Parts Number</td> <td>P.2</td> </tr> <tr> <td>Dimensions and Appearance</td> <td>P.2</td> </tr> <tr> <td>Constructions</td> <td>P.3</td> </tr> <tr> <td>Marking</td> <td>P.4</td> </tr> <tr> <td>Standard Rating</td> <td>P.4</td> </tr> <tr> <td>Performance Characteristics</td> <td>P.5 – P.6</td> </tr> <tr> <td>The measurement of Gold Capacitors</td> <td>P.7 – P.8</td> </tr> <tr> <td>Package Amount and Shape</td> <td>P.9</td> </tr> <tr> <td>Notes in using Electric Double Layer Capacitors</td> <td>P.10 – P.13</td> </tr> <tr> <td>•Individual Specification Sheets</td> <td></td> </tr> </table>		Notice matter	P.1	Scope	P.2	Parts Number	P.2	Dimensions and Appearance	P.2	Constructions	P.3	Marking	P.4	Standard Rating	P.4	Performance Characteristics	P.5 – P.6	The measurement of Gold Capacitors	P.7 – P.8	Package Amount and Shape	P.9	Notes in using Electric Double Layer Capacitors	P.10 – P.13	•Individual Specification Sheets	
Notice matter	P.1																								
Scope	P.2																								
Parts Number	P.2																								
Dimensions and Appearance	P.2																								
Constructions	P.3																								
Marking	P.4																								
Standard Rating	P.4																								
Performance Characteristics	P.5 – P.6																								
The measurement of Gold Capacitors	P.7 – P.8																								
Package Amount and Shape	P.9																								
Notes in using Electric Double Layer Capacitors	P.10 – P.13																								
•Individual Specification Sheets																									

Product Specification	EGC-HZ-475-1-1
Electric Double Layer Capacitor HZ series	1

Notice matter

- ◆ Law and regulation which are applied
 - This product complies with the RoHS Directive (Restriction of the use of certain Hazardous Substances in electrical and electronic equipment (DIRECTIVE 2002/95/EC).
 - No Ozone Depleting Chemicals(ODC's), controlled under the Montreal Protocol Agreement, are used in producing this product.
 - We do not PBBs or PBDEs as brominated flame retardants.
 - All the materials that are used for this product are registered as "Known Chemicals" in the Japanese act "Law Concerning the Examination and Regulation of Manufacture, etc. of Chemical Substances".
 - Export procedure which followed export related regulations, such as foreign exchange and a foreign trade method, on the occasion of export of this product Thank you for your consideration.
- ◆ Limitation of a use
 - This capacitor is designed to be used for electronics circuits such as audio/visual equipment, home appliances, computers and other office equipment, optical equipment, measuring equipment and industrial robots.
High reliability and safety are required [be / a possibility that incorrect operation of this product may do harm to a human life or property] more. When use is considered by the use, the delivery specifications which suited the use separately need to be exchanged.
- ◆ Country of origin : JAPAN
- ◆ Manufacturing factory : Capacitor Business Unit
Panasonic Electronic Devices Co.,Ltd.
25. Nishinaka. Kohata. Uji City. Kyoto
611-8585 Japan

Product Specification	EGC-HZ-475-1-1
Electric Double Layer Capacitor HZ series	2

1. Scope

This specification applies to Electric Double Layer Capacitors (Gold Capacitors) HZ series.

2. Parts Number

<u>EEC</u>	<u>HZ</u>	<u>0E</u>	<u>000</u>
2-1	2-2	2-3	2-4

2-1 EEC Electric Double Layer Capacitor

2-2 HZ HZ series

2-3 Maximum Operating Code
0E stands 2.5V

2-4 Capacitance Code : Indicating capacitance in uF by 3 letters.
The first 2 figures are actual values and the third denotes the number of zeros.

ex. 4.7F → 475

3. Dimensions and Appearance

Refer to individual specification sheet
Body Color (Black)

Electric Double Layer Capacitor HZseries

3

4. Constructions

4-1 Inside Construction

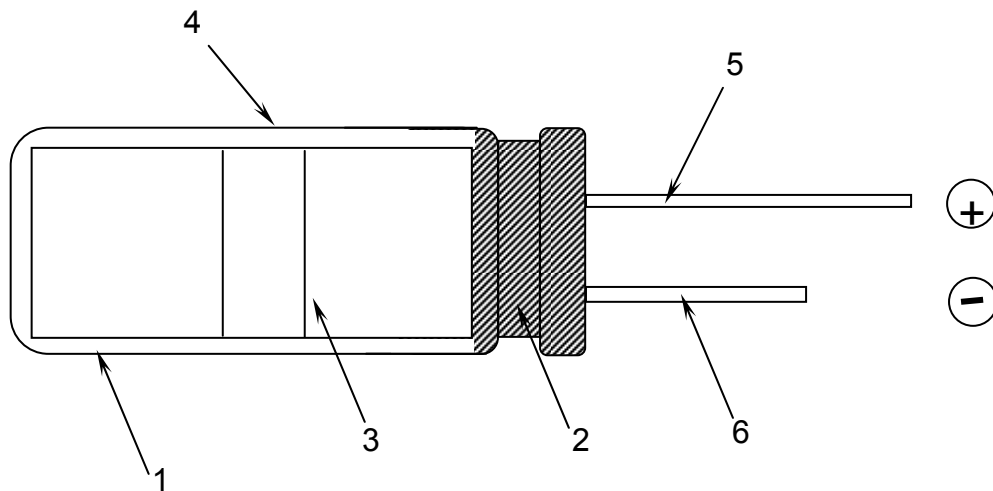

4-2 Construction Parts

NO	Name	Materials
1	Case	Aluminum
2	Rubber packing	Synthetic rubber
3	Internal elements	Aluminum Manila paper Activated carbon
4	sleeve	Polyester
5	+ Lead wire	Solid tinned copper weld steel wire
6	- Lead wire	Solid tinned copper weld steel wire

Electric Double Layer Capacitor HZ series

4

5. Marking

- (1) Nominal Capacitance(F)
- (2) Maximum Operating Voltage(V.DC)
- (3) Polarity(-)
- (4) Products Name(Gold Cap)
- (5) Date Code

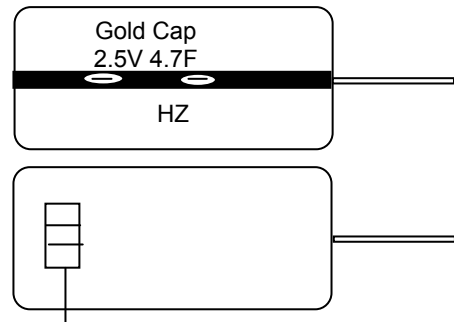

Production day.

1 to Y
(Excluded I, O and Q)

Production month. 1:Jan. 2:Feb.9:Sep. O:Oct. N:Nov. D:Dec

Production year. (The last digit number of a year) 6:2006 7:2007

6. Standard Ratings

No	Item	Ratings
		EECHZ0E***
1	Category Temperature Range	Refer to Individual Spec. sheet
2	Maximum Operating Voltage	Refer to Individual Spec. sheet
3	Nominal Capacitance	Refer to Individual Spec. sheet
4	Capacitance Tolerance	Refer to Individual Spec. sheet
5	Internal resistance	Refer to Individual Spec. sheet

Product Specification	EGC-HZ-475-1-1
Electric Double Layer Capacitor HZ series	5

7. Performance Characteristics

Test: Unless otherwise specified, the test shall be applied to JIS-C5101-1.

Initialization of test samples: The samples shall be measured after supplying 2.5V for 2hours with 300ohm resistance in the temperature (20 +/- 10°C, 65 +/- 10% not being wetted with dew) and discharging in short circuit for 12 to 24 hours.

No	Item	Performance	Test method
1	Capacitance	Reffer to individual specification sheet	Test shall be by the measurement(1)
2	Internal resistance	Reffer to individual specification sheet	Test shall be by the measurement(2)
3	Solder ability	Terminal to be covered with solder.	Immersion depth: 2 to 2.5mm from the root of terminal Solder temperature: 230 +/- 5°C Immersion time: 2.0 +/- 0.5s
4	Resistance to Soldering Heat	Capacitance change: <= +/- 10% of the initial measured value. Internal resistance: Item(2) value or less. Appearance: No remarkable damages.	Immerision depth: 2 to 2.5mm from the root of terminal Solder temperature: 260 +/- 5 °C Immerision time: 10 +/- 1 s
5	High temperature High humidity	Capacitance change: <= +/- 30% of the initial measured value. Internal resistance: <=2times of item(2) value. Appearance: No remarkable damages.	Test temperature: 55 +/- 2 °C Relative humidity: 90 to 95% Test time: 500 +24/-0 hours Note: No voltage applied
6	Endurance	Capacitance change: <= +/- 30% of the initial measured value. Internal resistance: <=4times of item(2) value. Appearance: No remarkable damages.	Test temperature: 60 +/- 2°C Test time: 1000 +48/-0 hours Applied voltage: 2.5V DC

Electric Double Layer Capacitor HZ series

6

No	Item	Performance	Test method																		
7	Shelf life characteristics	Capacitance change <= +/- 30% of the initial measured value. Internal resistance <= 2times of item(2) value. Appearance: No remarkable damages	Test temperature: 60 +/- 2°C Test time: 1000 +24/-0 hours Note: No voltage applied																		
8	Stability at low temperature and high temperature	2 Capacitance change: <= +/- 30% of value in step1 Internal resistance: <= 4times of value in step1	The capacitor under test shall be stabilized in range to temperature, at the temperature of 5steps, in order ,given in under table. <table border="1"> <thead> <tr> <th>Step</th> <th>Temperature (°C)</th> <th>Time</th> </tr> </thead> <tbody> <tr> <td>1</td> <td>+20 +/-2</td> <td>—</td> </tr> <tr> <td>2</td> <td>-25 +/-3</td> <td>—</td> </tr> <tr> <td>3</td> <td>+20 +/-2</td> <td>—</td> </tr> <tr> <td>4</td> <td>+60 +/-3</td> <td>—</td> </tr> <tr> <td>5</td> <td>+20 +/-2</td> <td>—</td> </tr> </tbody> </table> Electrical characteristics shall be measured at each temperature after 1hour interval. Because the temperature of the capacitor can be stabilized.	Step	Temperature (°C)	Time	1	+20 +/-2	—	2	-25 +/-3	—	3	+20 +/-2	—	4	+60 +/-3	—	5	+20 +/-2	—
		Step		Temperature (°C)	Time																
		1		+20 +/-2	—																
2	-25 +/-3	—																			
3	+20 +/-2	—																			
4	+60 +/-3	—																			
5	+20 +/-2	—																			
4 Capacitance change: <= +/-30% of value in step1 Internal resistance: Item(2) value or less																					
5 Capacitance change: <= +/-10% of value in step1 Internal resistance: Item(2) value or less																					
9	Heat shock	Capacitance change: <= +/-10% of the initial measured value Internal resistance: Item(2) value or less Appearance: No remarkable damages	Test temperature: low -25°C high +60°C Test time: left with no load at each above temperature for 30 minutes. Cycles: 5cycles Note: Test begins at low temperature.																		
10	Terminal strength	Tensile	JIS-C5101-1,4.13 Test condition(Ua,Ub)																		
		Bending		No fault such reeking or loosening of terminal to take place																	
11	Vibration	Capacitance change: <= +/-10% of the initial measured value Internal resistance: Item(2) value or less Appearance: No remarkable damages	JIS-C5101-1,4.17 Test class(a) 10 to 55 Hz																		

Electric Double Layer Capacitor HZ series

8.The measurement of Gold Capacitors

8-1 Capacitance[Measurement(1)]
Circuit

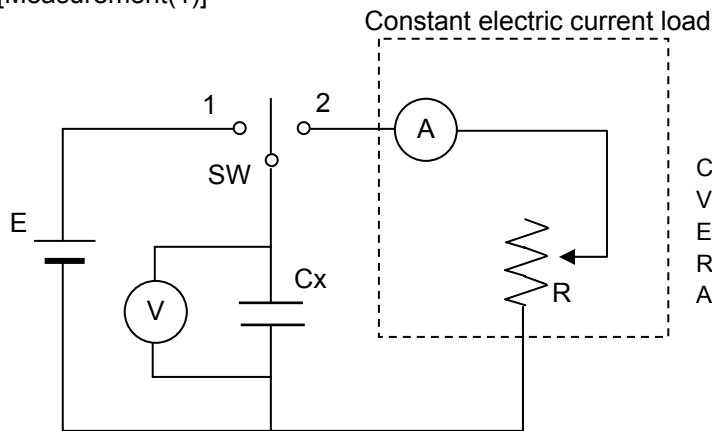

Cx: Capacitor under test
V: voltmeter
E: Constant voltage power supply
R: Constant electric current load
A: DC ammeter

(measurement)

- 1.Power supply E shall be set at 2.5V
- 2.After reaching maximum operating voltage at V measurement, the voltage shall be hold.
- 3.Switch shall be turned on toward side2 and the capacitor shall be discharged with the constant electric current 1mA/F through the constant load.
- 4.The time the capacitor terminal voltage drops from 1.0 to 0.5V shall be measured. After that, capacitance shall be calculated by the following formula.

$$C = \frac{I \times (T2 - T1)}{V1 - V2} \quad [F]$$

C[F]
 I[A]
 T2-T1[s]
 V1-V2[V]

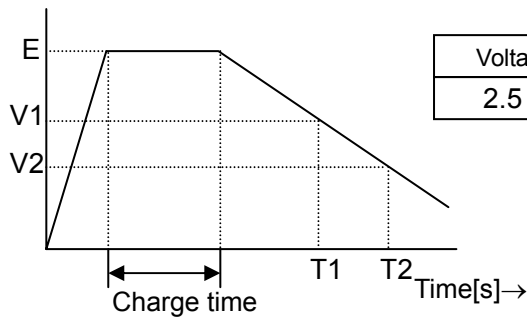

Voltage	V1	V2
2.5 V	1.0V	0.5V

Electric Double Layer Capacitor HZ series

8

Discharge current 10mA/F measurement can be applied instead of 1mA/F. Because 1mA/F discharge current measurement takes the longer time (V1 to V2) to discharge. In this case, capacitance will be affected by internal resistance and will be measured higher value than actual value.

If measured capacitance, capacitance tolerance, capacitance change rate on temperature characteristics or loading at high temperature are specified by 1mA/F in a catalogue or ENGINEERING APPROVAL SPECIFICATION.

8-2 Internal resistance[Measurement(2)]

Circuit

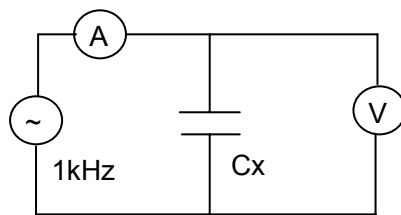

Cx: Capacitor under test

V: Voltmeter

A: AC ammeter

Measurement

1. Reading of A shall be rated at AC 1mA at 1kHz.
2. Reading of V shall be measured.

The internal resistance $Z[\Omega]$ shall be calculated the following formula.

$$Z = \frac{V}{10^{-3}} [\Omega]$$

Product Specification	EGC-HZ-475-1-1
-----------------------	----------------

Electric Double Layer Capacitor HZ series	9
---	---

9.Package Amount and Shapes

Capacitance(F)	Internal no. of pcs .	External no of pcs .
4.7	200	2000

Internal: Polyurethane bag
 External: Box

Product Specification	EGC-HZ-475-1-1
Electric Double Layer Capacitor HZ series	10

10. Notes in using Electric Double Layer Capacitors

Notice

1. Life time

Gold capacitors have a longer lifetime than secondary batteries, but their life is still limited. During use, capacitance decrease and internal resistance rises. Take sufficient back-up time into consideration when designing circuit. The lifetime of a Gold Capacitor is greatly affected by ambient temperature, applied voltage and operating current. By reducing these factors as much as possible, capacitor lifetime can be lengthened. Using products beyond end of the lifetime may change characteristics rapidly, short-circuit, operate pressure relief vent, or leak electrolyte.

2. Residual electric charge

Since Gold capacitors can hold great charge, there may be residual electric charge that could damage other low-withstanding voltage parts such as semiconductors.

3. Ambient temperature and humidity

•Capacitor life is affected by operating temperature. In general lowering ambient temperature by 10°C will double the life of a capacitor. Use the capacitor at the lowest possible temperature under the maximum operating temperature.

•Operation above the maximum specified temperature not only shortens capacitor life, but can also cause serious damage such as electrolyte leakage. Verify the operating temperature of the capacitor by taking into consideration not only the ambient temperature and temperature inside the unit, but also the radiation from heat generating elements inside the unit (power transistor, IC's, resistors, etc.) and self-heating due to ripple current. Be careful not to place heat-generating elements across from the capacitor on the opposite side of the PCB.

•The lifetime of GOOLD CAPACITOR is influenced by surrounding humidity. When humidity rises, the lifetime of GOLDCAPACITOR shortens. Especially, there is a possibility that lifetime shortens extremely due to rapid characteristic deterioration when using it in the environment of the high temperature and humidity.

4. Voltage drop during back-up operation

Take careful notice of the voltage drop caused by the instantaneous operating current and the internal resistance of the Gold Capacitor during the switch from power - failure - detection to back-up mode. Because internal resistance varies by product, use the following table to decide the correct operating (discharge) current.

Series	Operating current		
	1.5F or less	3.3F to 4.7F	10 to 50F.
HZ	100mA or less	300mA or less	1A or less

5. External sleeve

External sleeve is not intended to ensure the electrical insulation, and thus capacitors should not be used in the environment that requires electrical insulation.

Electric Double Layer Capacitor HZ series

11

6. Heat stress during soldering

Excessive heat stress may result in the deterioration of the electrical characteristics of the capacitor, loss of air-tightness, and electrolyte leakage due to the rise in internal pressure.

- If the tip of the soldering iron touches the capacitor's external sleeve, the sleeve will melt or break.
- Use the general reference chart to set soldering temperature and time.

1) In case of soldering by soldering iron

In use the soldering iron (30W or under), solder at the iron tip temperature not more than 350°C within 4seconds. Do not touch the iron tip to the body of Gold Capacitor.

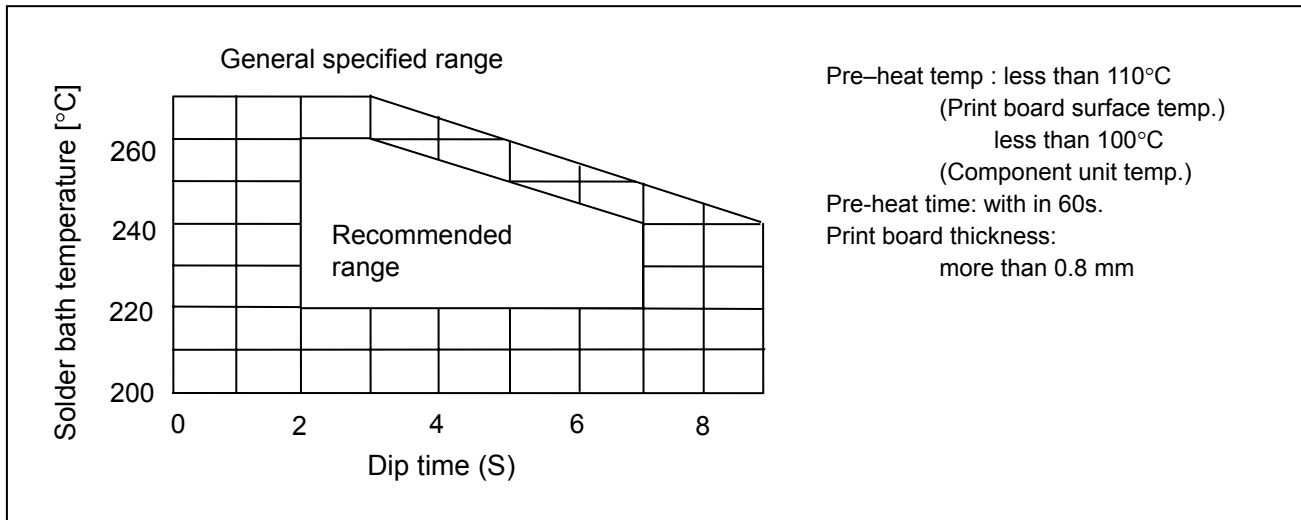

7. Brown extraction

A brown extraction might be caused in the sealing part depending on use conditions. This extraction is insulation. Therefore, it doesn't have the influence in the electric characteristic.

Product Specification	EGC-HZ-475-1-1
Electric Double Layer Capacitor HZ series	12
<p>Caution</p> <p>1.This specification guarantees the quality and performance of the product as individual components. Before use, check and evaluate their compatibility with installed in your products.</p> <p>2.Do not use the products beyond the specifications described in this document.</p> <p>3.Electrolyte is used in the products. Therefore, misuse can result in rapid deterioration of characteristics and functions of each product. Electrolyte leakage damages printed circuit and affects performance, characteristics, and functions of customer system.</p> <p>4.Over Voltage If Gold Capacitor is used at a voltage exceeding its maximum operating voltage, not only is its lifetime shortened but also depending on the actual voltage, gas generated by electrochemical resections inside the capacitor may cause it to leak or rupture.</p> <p>5.Polarity Be sure to verify the polarity of the capacitor before use. If a reverse voltage is applied for a long time, capacitor lifetime is shortened and serious damage such as electrolyte leakage may occur.</p> <p>6.Ripple current Gold Capacitors have a higher internal resistance than electrolytic capacitors and are more susceptible to internal heat generation when the temperature of the element rises, reaction current flows inside the Gold Capacitor, generating reaction products and raising internal resistance even further. This makes it difficult to maintain capacitor temperature 3°C measured at the surface of the capacitor.</p> <p>7.Connection capacitors in series Taking into consideration the possibility of an imbalance in the voltage across the capacitors, make sure that the voltage applied to each capacitor will not exceed the maximum operating voltage. If the voltage balance breaks down, an over voltage condition could result. To prevent this from occurring, add a voltage-driving resistor in parallel with each capacitor, allowing the capacitor's leakage current.</p> <p>8.Environmental conditions Avoid the use of capacitors at a temperature above the maximum operating temperature. In this case, it may cause the increase of electrolyte vapor pressure and the gas generation by electrochemical reactions which result in inner-pressure rise, serious damage and electrolyte leakage.</p> <p>9.Mounting considerations Double-side circuit board Do not set wiring pattern directly to the mounted capacitor, and pass between terminals. If the electrolyte leaks, short circuit may occur and tracking or migrations are anticipated. Through hole board Do not locate the capacitor close to circuit board. Solder blowing out of the holes possibly causes the short circuit.</p> <p>10.Do not apply any strong force to the capacitor after circuit installation has been completed.</p> <p>11.Do not use glue, which contain a halogen.</p> <p>12.Circuit board cleaning Circuit boards can be immersed or ultrasonically cleaned using suitable cleaning solvents for up to 5minutes and up 60deg.C maximum temperatures. The board should be thoroughly rinsed and dried. [Recommended cleaning solvent include] Pine Alpha ST-100s, Sunelec B-12, DK be-clear CW-5790, Aqua Cleaner 210SEP, Cold Cleaner P3-375, Cclear-th-ru 750H, Clean-thru 750L, Clean-thru 710M, Techno Cleaner219, Techno Care FRW-17, Techno Care FRW-1, Techno Care FRV1 Depending on the cleaning method, the marking on a capacitor may be erased or blurred. ◆ Consult with us if you are using a solvent other than any of those listed above. ◆ The uses of ozone depleting cleaning agents are not recommended in the interest protecting the environment.</p>	

Product Specification	EGC-HZ-475-1-1
Electric Double Layer Capacitor HZ series	13
<p>13. Install the following systems for a failsafe design to ensure safety if these products are to be used in equipment where a defect in these products may cause the loss of human life or other significant damage, such as damage to vehicles (automobile, train, vessel), traffic lights, medical equipment, aerospace equipment, electric heating appliances, combustion/gas equipment, rotating equipment, and disaster/crime prevention equipment.</p> <ul style="list-style-type: none"> >The system is equipped with a protection circuit and protection device. >The system is equipped with a redundant circuit or other system to prevent an unsafe status in the event of a single fault. >Please execute the check or exchange the GOLD CAPACITOR periodically. <p>14. Before using the products, carefully check the effects on their quality and performance, and determine whether or not they can be used. These products are designed and manufactured for general-purpose and standard use in general electronic equipment. These products are not intended for use in the following special conditions.</p> <ul style="list-style-type: none"> • In liquid, such as Water, Oil, Chemicals, or Organic solvent • In direct sunlight, outdoors, or in dust • In vapor, such as dew condensation water of resistive element, or water leakage, salty air, or air with a high concentration corrosive gas, such as Cl₂, H₂S, NH₃, SO₂, or NO₂ • In an environment where strong static electricity or electromagnetic waves exist • Mounting or placing heat-generating components or inflammables, such as vinyl-coated wires, near these products • Sealing or coating of these products or a printed circuit board on which these products are mounted, with resin and other material • Using solvent, water or water-soluble cleaner for flux cleaning agent after soldering. (In particular, when using water or a water-soluble cleaning agent, be careful not to leave water residues) <p>15. Please arrange circuit design for preventing impulse or transitional voltage. Do not apply voltage, which exceeds the full rated voltage when the capacitors receive impulse voltage, instantaneous high voltage, high pulse voltage etc.</p> <p>16. Do not store capacitor under any of the environment conditions listed below.</p> <ul style="list-style-type: none"> • At high temperature and high humidity. • Where the capacitor is subject contact with water, salt water or oil. • Where the capacitor is exposed to direct sunlight or to toxic gases. • Where there is a lot of dust in the air. <p>17. Emergency procedures If capacitors overheat or start to smell, immediately switch off the unit's main power supply to stop operation. Keep your face and hands away from the capacitor, since the temperature may be high enough to cause the capacitor to ignite and burn.</p> <p>18. Capacitors disposal When disposing of capacitors, follow the instructions below.</p> <ul style="list-style-type: none"> • Crush or make a hole in the capacitor before burning. If the capacitor is burned without making a hole, it can explode. If taking apart the capacitor before disposal, wear protective gear such as gloves and goggles. • If you choose not to burn used capacitors, consign them to a specialized industrial waste processor for disposal. <p>The application guidelines above are taken from: Technical report EIAJ RCR-2370 issued by the Japan Electric Industry Association, Inc. "Guideline of notable for fixed electric double layer capacitors with non-solid electrolyte for use in electric equipment." For further details, please refer to this Technical Report.</p>	

Electric Double Layer capacitors

EB-HZ-475

Gold capacitor HZ Series

Part Number EECHZ0E475

Category temperature range -25°C~+60°C

Polarity - : NEGATIVE

Capacitance (F) 4.7

Capacitance range 3.96 ~ 6.58

Maximum operating voltage 2.5

Internal resistance 0.3(f=1kHz)

外觀寸法図 (単位:mm)

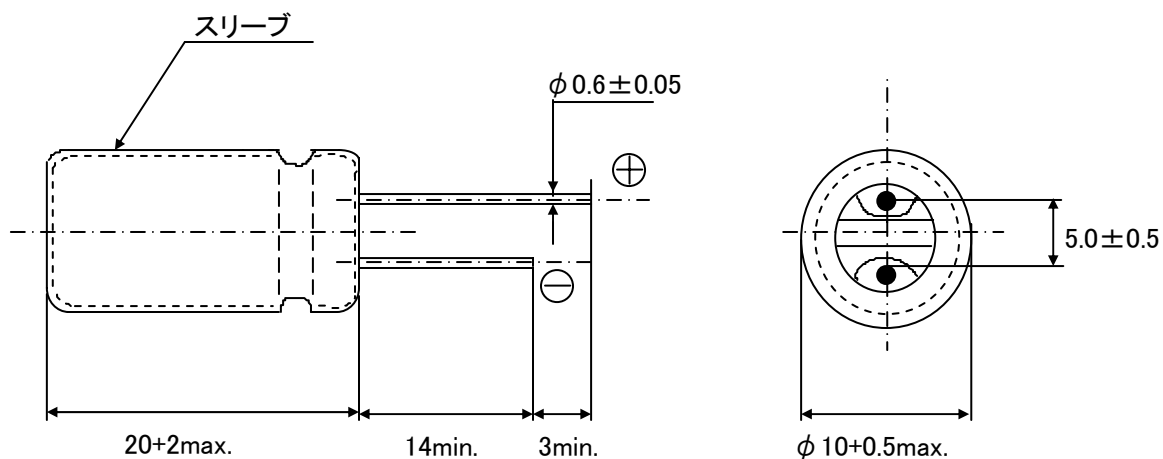

Note

Taking into consideration the possibility of an imbalance in the voltages across the capacitors, make sure that the voltage applied to each capacitor will not exceed the maximum operating voltage.

--	--

Issue	2007.3.8	Panasonic Electronic Devices Co., Ltd.
Revision		